

# RC Timers and Timing Circuits

Bill Sheets  
K2MQJ

Rudolf F. Graf  
KA2CWL

Timers and timing circuits are used in a wide variety of applications. From short time delays of a few nanoseconds used in digital circuitry and computers, to long periods of thousands of hours, used to control daily, weekly, or yearly events, electronic circuits can provide this function reliably, accurately and repeatably, with no need to provide any user input or monitoring once the time has been set. While most timers used for everyday applications in consumer goods are now implemented with or are part of a microcontroller system, for simple applications this is not always necessary. The use of a simple circuit based on a 555 type timer or a multivibrator may be more appropriate in these cases. Where high accuracy is needed a crystal oscillator and a divider chain can be used. There are a number of CMOS logic chips useful for this purpose. R-C or L-C circuits are useful where timing errors of a few percent are acceptable, but where accurate timing is a must, crystal oscillators or other circuits using stable resonators should be used. The oscillator circuit is often referred to as the clock, since it generates time intervals that are counted in some way to produce the desired timing interval. However, the simplest timers are based on the charging and discharging of a capacitor through a resistor or current source. This approach has been around for a long time, even though its accuracy is somewhat limited (1-10 percent). We will confine this discussion to timers using RC (resistor-capacitor) components as timing elements. First, a few basic concepts.

The voltage across a capacitor is equal to the charge on it divided by the capacitance, in any consistent system of units. Charge is usually measured in Coulombs, and capacitance in Farads. Current is defined as a flow of charge. The Ampere, or unit of current, is defined as that current produced by one coulomb of charge flowing across a given surface in one second. A one ohm resistor will show a 1 volt drop across it with one ampere (or one coulomb per second) flowing through it. In a practical situation, the presence of one ampere of current in a wire signifies that one coulomb of charge flows past a given point in one second. A one farad capacitor will have a charge of one coulomb when there is one volt of potential difference between the plates. If we connect a one ampere current source across a one farad capacitor, the voltage across it will rise at the rate of one volt per second, continuing to rise at this rate as long as the charging current remains constant. By knowing the current and the capacitance, we can accurately predict how long it will take to reach a certain voltage. This voltage may be that needed to produce some desired action. Conversely, if we know the capacitance, final voltage needed to produce that action, and the time delay desired, we can calculate the necessary charging current. This can be used as a basis for a timer circuit.

However, the problem in real life is that one farad capacitors and ideal 1 ampere current sources are not very practical to use. One farad capacitors are usually of the memory backup type limited to low voltages used in logic circuitry, and units rated at 15 volts or so are physically very large and expensive. One ampere current sources involve extra electronic circuitry and are limited as to output voltages they can achieve and still maintain one ampere current flow. This at best would be a few hundred volts, and practically speaking, could be dangerous to work with. Much smaller capacitors of a few microfarads or less and much lower charging currents are used in practice. This allows use of standard size electronic components. But it is not necessary to use an ideal current source either. A voltage with a series resistance can be used instead.

See Fig 1, a basic R-C charging circuit. This circuit is generally well covered and “beat to death” in elementary electronics texts. When the switch S1 is closed and S2 is opened, voltage V is applied to the circuit. C1 has initially (and ideally) zero voltage across it and an initial current equalling  $V/R$  flows. However, the voltage across C1 starts to rise, and now the voltage across R1 is slightly less. This causes the charging current to drop. This process continues, the current dropping

as the capacitor charges toward a final value equal to the voltage V. The exact waveform of the current is given by the mathematical plot of the function  $e^{-\alpha t}$  where  $\alpha = 1/RC$  and  $t = \text{time}$ . If one writes the loop equations for this circuit as follows:

$$V = IR + Q/C \quad \text{where } I = i(t) \text{ a function of time} \quad Q = \text{charge on capacitor}$$

The quantities  $V = \text{supply volts}$   $C = \text{Capacitance}$   $R = \text{resistance}$  are all constant

Then  $V - I(t)R = Q/C$  If  $V$  (supply voltage) is constant and the value of  $C$  is also constant, then remembering that the current  $I$  is defined as the rate of flow of charge per unit time:

$$\Delta V / \Delta T - [\Delta I(t) / \Delta T] R = (\Delta Q / \Delta T) / C \quad \Delta \text{ symbolizes "change of"}$$

This can be expressed mathematically using derivatives. A derivative of a mathematical function is the rate of change of one variable (current) with respect to another variable (time). If the rate of change is rapid the derivative is large. If the function is a constant (no change) the derivative is zero. If two functions are identical then their derivatives at a point are equal. Therefore

$$dV / dt - [di(t) / dt] R = (dQ / dt) / C$$

Now remember that current is the rate of flow of charge with respect to time past a given point. Therefore  $i(t) = dQ / dt$ . We said that the supply voltage  $V$  is constant and does not change with time so  $dV / dt$  is zero. Therefore:

$$- [di(t) / dt] R = i(t) / C \quad \text{or dividing both sides by } R$$

$$di(t)/dt = i(t) / RC \quad \text{and therefore}$$

$$di(t)/dt + i(t) / RC = 0$$

This differential equation says that  $i(t)$  has a rate of change with respect to time that equals the original current  $I(t)$  divided by  $RC$ , or it is its own derivative divided by a constant, which is  $RC$ . The mathematical function that has this property is equal to  $e$  raised to the power  $(-t/RC)$ , written as  $e^{-(t/RC)}$ . " $e$ " is the base of natural logarithms and is a natural constant which is approximately equal to 2.71828..... (See a math book, it has a lot more decimal places). If this function is plugged into the relationship above the equation is satisfied, indicating that indeed this is a solution to the differential equation. This exponential waveform has the shape shown in Fig 1. Note that it starts at a maximum and decays to zero. This is called the exponential decay and is characteristic of many natural processes (cooling off of a hot object, radioactive decay, certain chemical reactions, etc.) We are not going any further here with the math, get out your high school advanced algebra books if you are lost.

As we said before, the voltage across the capacitor increases towards the supply voltage  $V$ . As the current drops exponentially the voltage drop across  $R$  drops in an identical fashion. The capacitor voltage is the voltage  $V$  (power supply voltage) minus the  $IR$  drop. However, the capacitor voltage never quite reaches  $V$ . The product of  $R$  and  $C$  is called the time constant. It has the units of seconds. If  $R$  is in megohms then  $C$  is in microfarads. Therefore a 1 megohm resistor and a 1 microfarad capacitor (very practical values) have a time constant of 1 second. In one time constant the capacitor voltage will be 63 percent of the source voltage. The current in  $R$  will be 37 percent of initial value. In two time constants it will reach a little more than 86 percent of the supply voltage, the current about 14 percent of initial. And after three time constants it will be 95 percent. With 5% current flow. After five time constants it will be over 99 percent and the current will be less than one percent of initial value. But it never can equal the supply voltage, since this would require zero voltage across  $R$  and therefore there would be zero current flow to get that "final step". Mathematically we say that the function  $e^{-(t/RC)}$  approaches a limit of zero as time approaches infinity. Physically, it will never actually get there, but given enough time, will approach as close as

you like. The reason we mention this is to dispel a popular misconception that any RC timing circuit will have a time period equal to RC. The time period depends on both the RC product and the initial voltages across the capacitor or the resistor, as well as the final voltage needed to produce the required actions in the circuit. Therefore R-C timers can be severely affected by the circuit supply voltage, unless suitable precautions are taken to compensate them for voltage variation. The R-C circuit is usually reset by discharging the capacitor, preferably through some low resistance so as to limit the discharge current to a safe value. S2 is used for this function. As this was simply a demo circuit, no resistance was used. The discharge time constant would be RC, with R equalling the resistance of the switching circuit

Fig 2 shows a very simple timing circuit using a single transistor and an R-C timing circuit. This was used to switch on device via a LED – photocell arrangement (optocoupler). It produces a delay on powering up to ensure correct sequencing of certain equipment. C1 charges toward the power supply voltage (12 volts) through R1. When the voltage reaches 9.1 volts, zener diode D1 conducts, forward biasing the transistor Q1, turning it on. At about 9.8 volts, the zener diode and base of Q1 conduct heavily, taking the charging current from C1. C1 can charge no higher and ceases to draw current. When power is turned off, the circuit is reset by C1 discharging through R1 into the now zero voltage supply. The time can be varied by changing R1, C1. The zener voltage of D1, or the supply voltage. Note that the 2.2K resistor and 100 uF capacitor have a time constant of 0.22 seconds, but the actual delay time is about 0.37 seconds, since the capacitor has to charge to about 82 percent of the supply voltage, which takes 1.7 time constants, and this is  $1.7 \times 0.22 = .374$  sec. If the 12V power supply malfunctioned and increased to 15 volts, the capacitor would have to charge to  $9.8/15$  or 64 percent of the supply voltage. This would take slightly more than 1 time constant, 1.015 to be exact, and this would decrease the delay time of this circuit to close to 0.22 seconds. Note the change in delay time with supply voltage. This could cause premature turn on of the external controlled device with possible serious consequences. In practice, a critical function such as this would be handled by a microcontroller or other more sophisticated controller system, but the circuit shown demonstrates the principle.

Circuits using op amps can also be used as timers. In these circuits, voltage levels needed to set “trip points” can be derived from resistor divider networks, and the trip or reference voltages are determined by ratios of resistor values, rather than absolute voltage levels. This helps them to be independent of supply voltages. Now operating conditions are determined by percentages of power supply voltage, not fixed parameters. The reference voltages will directly track the power supply voltages, automatically compensating for variations. A simple circuit is shown in fig 3. In this circuit an op amp is used as a comparator. The reference voltage is derived from the power supply by the use of a resistive divider Ra and Rb and sets a level at the inverting input of the amplifier. C1 normally would charge toward the power supply voltage Vcc if not for the switch transistor Q1. For purposes of explanation, assume  $R_a = R_b$ . Then the reference level will be half the supply voltage. Initially the op amp output voltage will be at its low limit, close to zero volts, since the capacitor voltage is held at zero by a switching transistor Q1 that is biased on. When Q1 has its bias removed, it will cease conducting. Now C1 charges toward the supply voltage. When it reaches half of this voltage, its voltage will equal the voltage at the inverting input of the op amp as set by Ra and Rb. When this voltage is passed, the op amp, having very high gain, will switch and its output will rise to nearly the supply voltage at this point. The time that this occurs will be at a time interval equalling 0.692 times the RC time constant, since at this point the voltage on the capacitor will reach half the supply voltage. The op amp output voltage could be used to switch on Q1 by controlling the bias on it. This would either end the cycle or cause it to repeat, depending on the exact way it was done. A circuit called a flip-flop could be used to do this. A flip flop is an elementary memory circuit having two stable states, much like a toggle switch, and is controlled by applying a level or pulse to its inputs. This principle is used in a very popular integrated circuit used as a timer, the NE555

The NE555 timer and its various related types are probably among the 10 most popular and widely used IC devices of all time. The NE555 has existed for about thirty years and is a staple among experimenters. While the 555 is available in bipolar and CMOS types (7555), the CMOS

versions may prove to be somewhat more useful for many experimenter applications. This is because the higher circuit impedances allow more reasonable values of R and C components, especially important where long time delays are required. These devices come in a DIP (dual inline) 8 pin package in thru hole and surface mount. A dual timer, the NE556 is also available, as well as a quad version, the NE558. The NE555 is very versatile and can be used as an astable (free running) timer/oscillator, or as a one shot (monostable) triggered timer. Fig 4 is a block diagram of the 555 device. It consists of two comparator amplifiers, a flip flop, an output driver and a discharge transistor. A single external resistor R and capacitor C determine the time interval. The comparators are internally referenced by an internal resistive voltage divider at 1/3 and 2/3 of the supply voltage. The 2/3 voltage is brought out to a separate pin. This pin is often unconnected or bypassed to ground in many applications. The collector of the discharge transistor is also brought out to a separate pin. A reset input is provided to reset the flip flop. The bipolar NE555 can output 200 mA with a 15 volt supply, enough to directly drive many small loads. The pulse width can be from about a half a microsecond to up to around an hour, depending on external components. About 20 to 30 minutes is about the maximum practical limit. Beyond this limit an external countdown scheme using a frequency divider can be implemented.

A circuit to generate a pulse is shown in Fig 5. In this circuit the flip flop internal to the 555 is normally set so that the discharge transistor is conducting. A negative going trigger or pulse is applied to the trigger input. This input is that of the lower comparator and is biased at 1/3 Vcc. The trigger must be negative going so as to drive the input below 1/3 VCC. Generally an AC coupling capacitor is used so as not to upset the DC level here. This causes the comparator to change the state of the flip flop, cutting off the discharge transistor. External capacitor C1 starts to charge through R1 until it reaches 2/3 Vcc. This takes about 1.1 time constants. At this point the upper comparator changes its state and resets the flip flop. This causes the internal discharge switch transistor to turn on, discharging C1. Note that the trigger to the lower comparator must be removed by this time, or else erroneous operation will result. Since the discharge transistor is directly connected to the threshold input and across the capacitor, this action is very rapid. The generated pulse appears at the device output pin, and has a period of close to 1.1 RC. This circuit can be used to trigger another timer circuit. Triggering in this mode occurs on the negative going edge of the trigger pulse. Once the circuit is triggered, it will complete its cycle with no regard to extra triggers during this period. Resetting can be done via a pulse applied to the reset input. This resets the flip flop and turns on the discharge transistor.

The 555 can be used as an oscillator, with one extra resistor needed to do this. Fig 6 shows this configuration. The trigger pin is tied to the threshold pin. R1 is split into 2 parts Ra, and Rb, and the discharge transistor is connected to their junction. When power is applied the capacitor C1 charges toward Vcc until 2/3 Vcc is reached. At that point the discharge transistor turns on, discharging C1 through Rb until 1/3 Vcc is reached. At this point the comparator trips and the discharge transistor turns off. Now the capacitor C1 charges again to 2/3 Vcc until this voltage is reached. The capacitor voltage will switch between 1/3 Vcc and 2/3 Vcc. Note that on startup the first cycle is longer since the capacitor must charge between zero and 2/3 Vcc. On subsequent cycles it starts from 1/3 Vcc, so the time for charging will be shorter. The formula for the frequency is given by:

$$F = 1.49 / (Ra + 2 Rb)C1$$

Note that by varying the ratio of Ra to Rb, the duty cycle can be varied. However, there is a problem. Since the charging path is through Ra + Rb and the discharge path through Rb, they can never be equal. This makes a 50 percent duty cycle unachievable with this circuit, since Ra + 2 Rb always will be > Ra unless Ra is made to be zero. This problem can be corrected by using two diodes (1N914 types, etc.) to steer the charge and discharge paths through only Ra and Rb respectively. In practice this allows less than 5% to more than a 95 % duty cycle to be achieved. Note that due to device limitations Rb must be greater than about 3kΩ for reliable performance. This is shown in Fig

7.  $R_a$  and  $R_b$  could be incorporated into a potentiometer to adjust the duty cycle, with  $C$  being used to set the frequency.

Another mode of operation is that of providing a time delay. In monostable operation a pulse lasting for a predetermined time is generated immediately on triggering. The output goes high immediately and times out after the predetermined time. In time delay operation it is desired to have a state change only after a delay. In this mode (see fig 7) the internal discharge transistor is not used. The threshold and trigger are tied together. The capacitor  $C$  is instead discharged upon the application of a triggering pulse to the transistor. When this transistor is turned on,  $C$  is kept discharged. This keeps the trigger and threshold low, and the timer output is forced low. When a negative going level is placed on the base of the triggering transistor, it is cut off. The capacitor charges toward the supply voltage, and then when the threshold voltage is reached, the output now changes state. The output will then remain unchanged until the triggering transistor is turned on.

Circuits using this device will be discussed in the next part of this article.

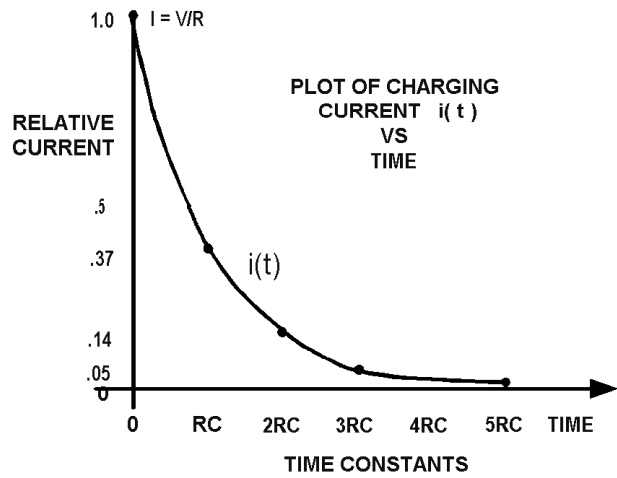
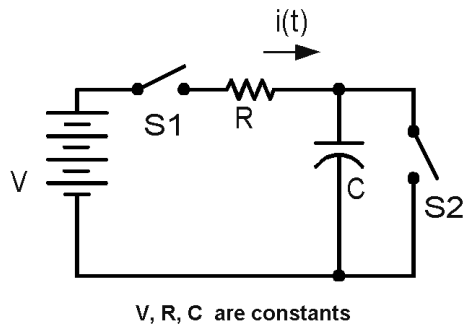

**FIG 1 R-C CHARGING CIRCUIT**

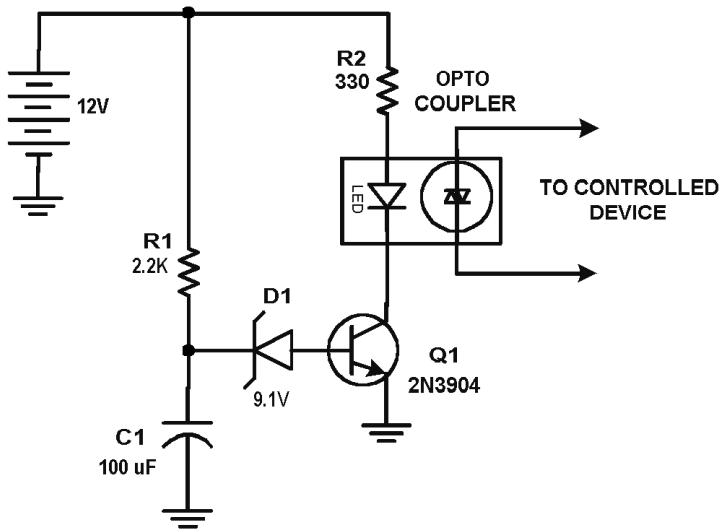

THIS CIRCUIT PRODUCES A DELAY IN TURNING ON THE OPTOCOUPLER USING COMPONENTS R1, C1, D1, AND Q1

**FIG 2 SIMPLE TIMER CIRCUIT**

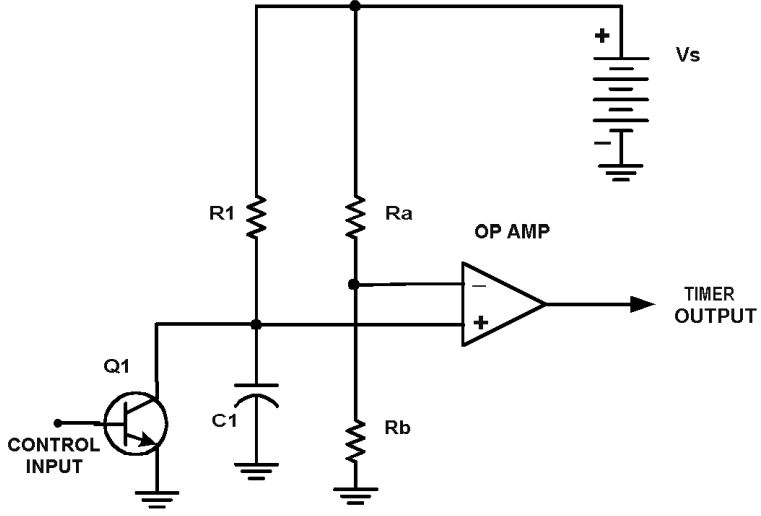

FIG 3 OP AMP TIMER

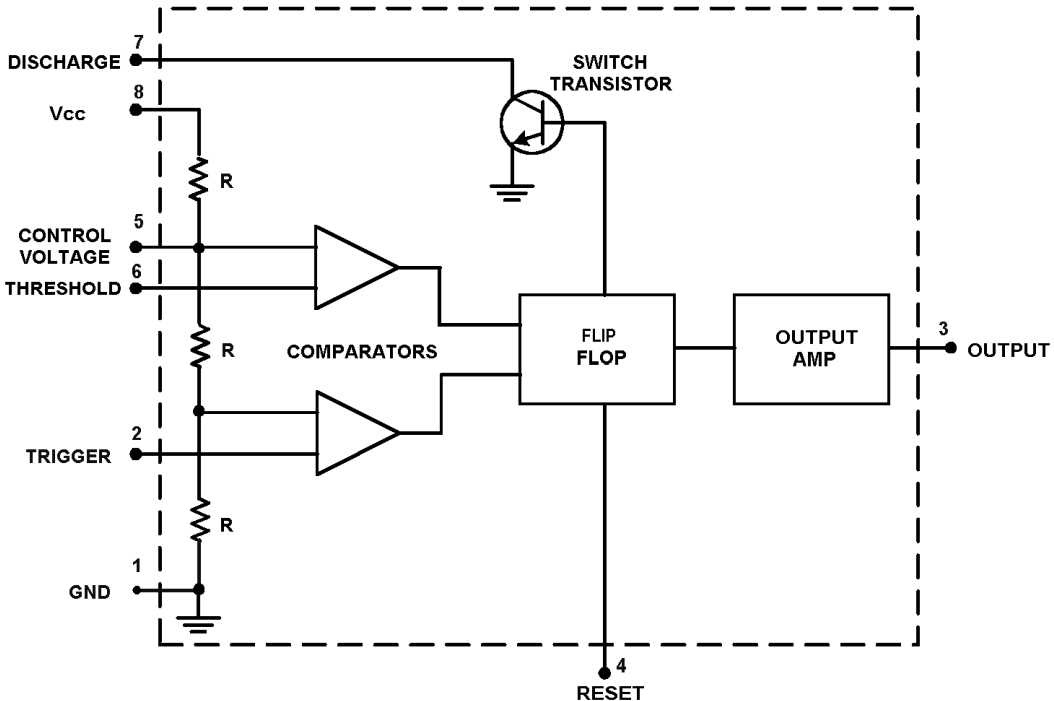

FIG 4 NE555 BLOCK DIAGRAM

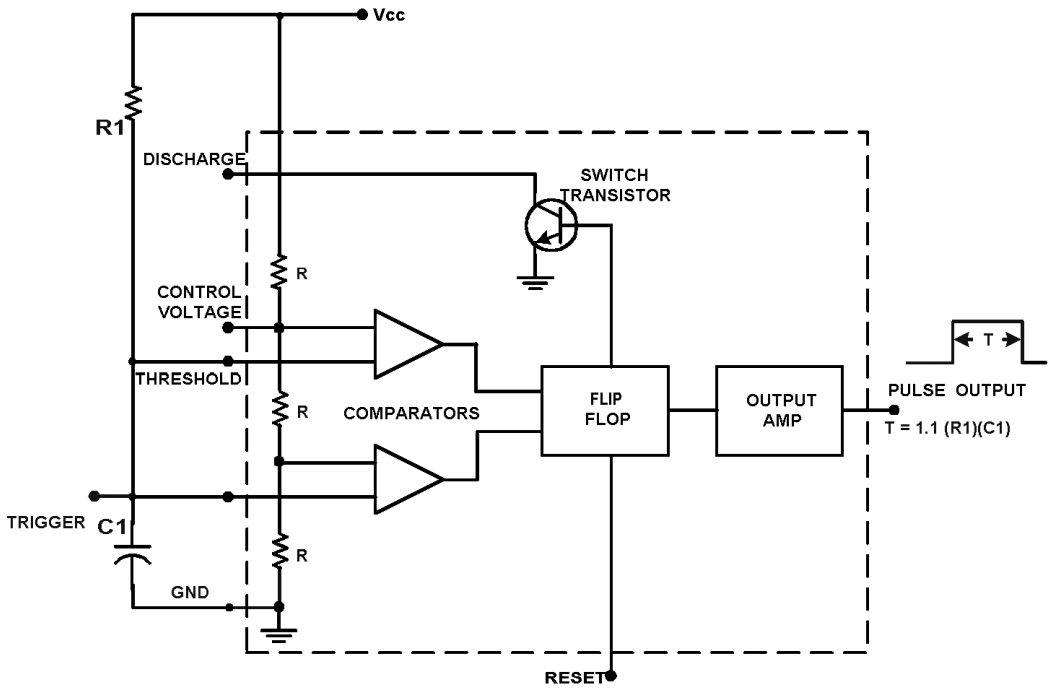

FIG 5 MONOSTABLE OPERATION OF NE555 TIMER

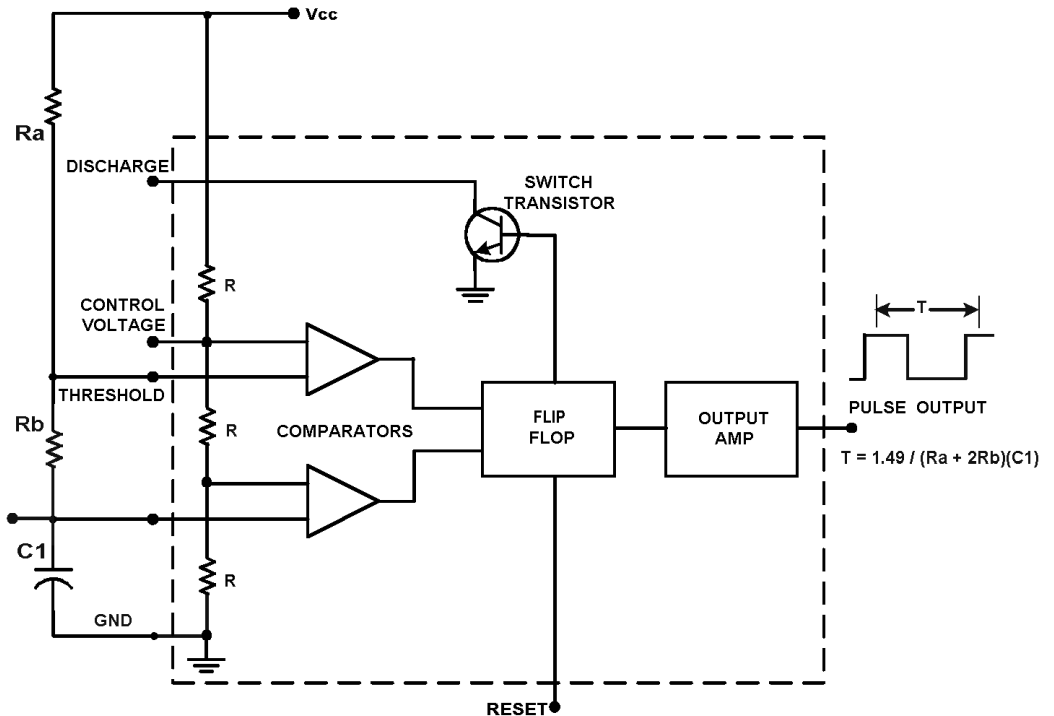
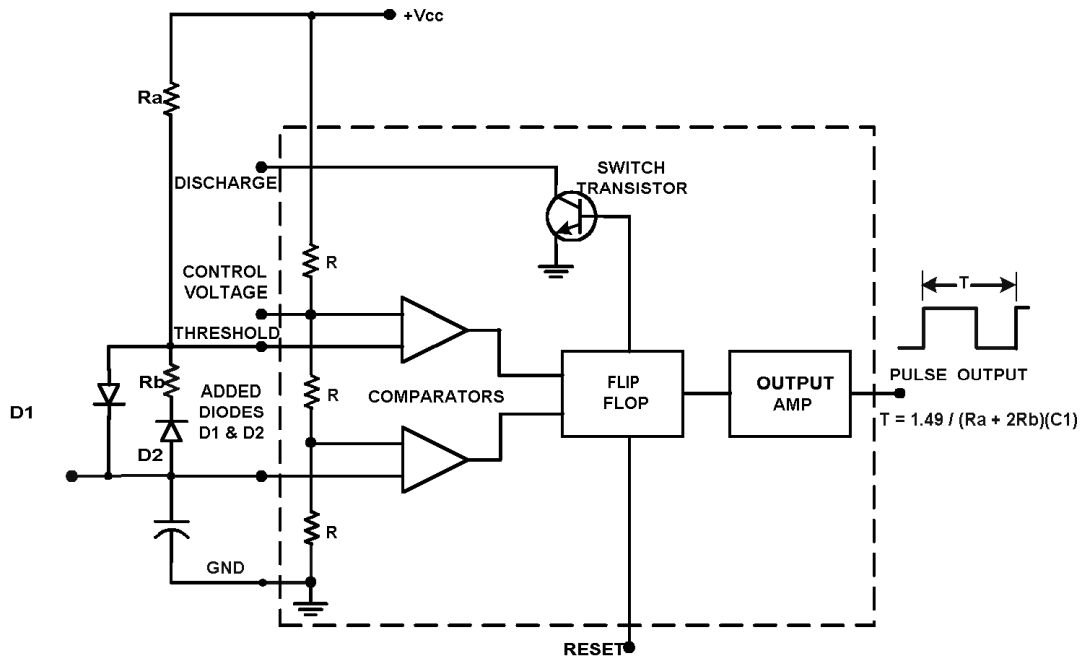
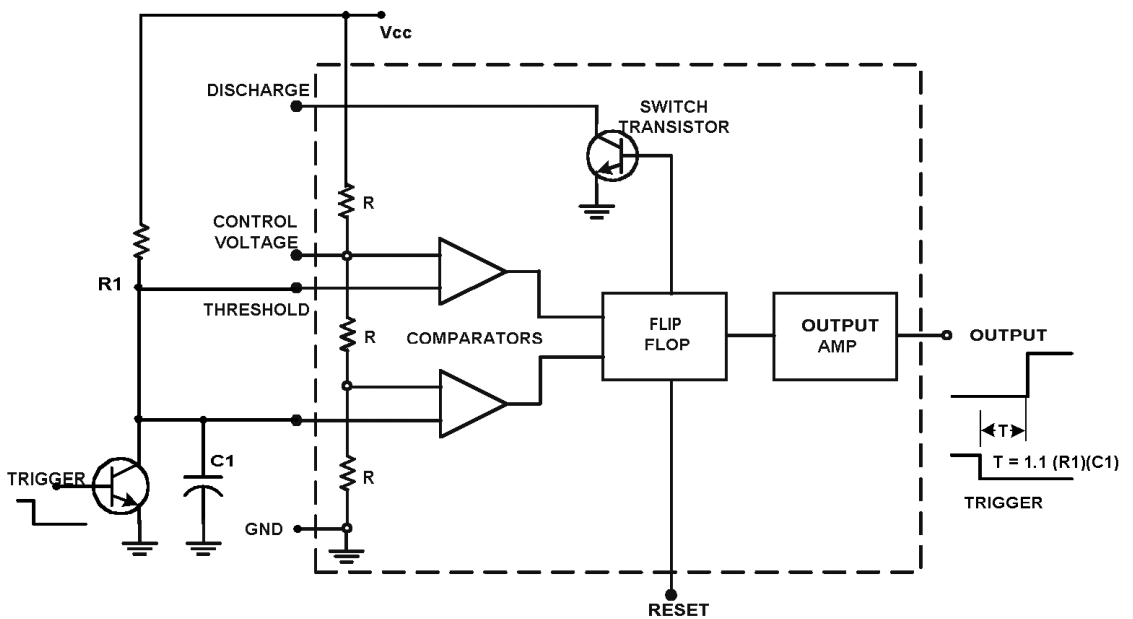

FIG 6 ASTABLE OPERATION OF NE555 TIMER





**FIG 7 ASTABLE OPERATION OF NE555 TIMER WITH DUTY CYCLE CONTROL**



**FIG 8 TIME DELAY OPERATION OF NE555 TIMER**